

Firebreak Service Transits

TECHNICAL DATA SHEET

Firebreak Service Transits comprise a range of circular and rectangular devices designed to be installed in fire resistant walls and floors where cables and other services are required to penetrate. Once installed the Transits become a 'dry system' especially suited to situations where frequent changes to services is a requirement. The especially formulated fully durable intumescent provides up to four hours fire resistance across the full range of Transit sizes.

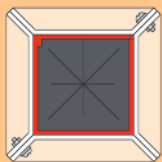

Single

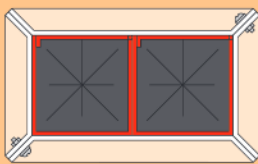

Duplex

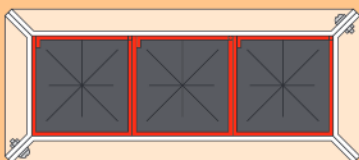

Triplex

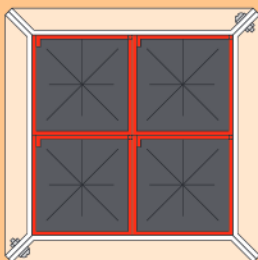

Quadplex

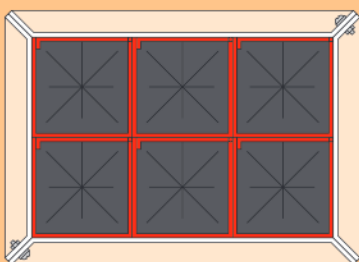

Sixplex

Description

Firebreak Service Transits are designed to maintain the fire resistance of floor and walls when penetrated by electrical cables, small plastic pipes and small metallic pipes with combustible foam rubber insulation. Under fire conditions the foam plugs at each end on the Transit restrict the passage of smoke whilst the intumescent filler at the core expands to many times its original thickness closing the opening with a dense block of fire resistant char.

The transits are either circular or rectangular and are manufactured with a durable powder coated steel outer casing. Each transit is hinged to allow for retro-fitting around services which are already installed. Once in place it is a simple process to remove or add new services at a later date without the need for wet trades.

Circular Transits range in size from 50mm to 150mm Ø. Rectangular Transits range in size from 65mm x 65mm all the way up to 125mm x 1100mm – the latter being able to accommodate two 500mm wide cable baskets positioned side by side. The smaller rectangular Transits can be grouped together in twos, threes, fours and sixes.

All transits can be supplied with purpose designed galvanised steel mounting flanges including flanges designed for use with grouped Transits.

Performance

Firebreak Service Transits are tested to the latest European requirements for applications in walls and floors.

- Fire Classification to EN 13501-2 and CE Mark (ETA 21/0207)
- Flexible Walls (stud partitions) or rigid walls (masonry, concrete) of 100mm minimum thickness
- Rigid (concrete) floors of 150mm minimum thickness
- Up to 4 hours fire resistance (EI240) covering a wide range of cable types and sizes, cable baskets, metal pipes with continuous combustible insulation and small plastic pipes
- Mechanical and durability testing to EAD 350454-00-1104; Y₂ (internal use within full ambient temperature range inclusive of temperatures less than 0°C)
- Third party product certification with UL International (Certificate # UL-EU-00772)

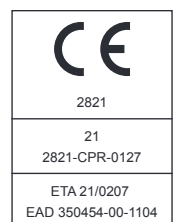

Electrical cables in dry line or concrete block/masonry walls of minimum thickness 100mm

Transit size (mm)	Penetrating service	Fire performance (mins)	
		Integrity (E)	Integrity & insulation (EI)
65 x 65, 102 x 102, 50, 100 & 150 Ø	Electrical cables up to 80mm Ø	120	30
	Unsheathed wire up to 24mm Ø	120	30
	Telecoms cables in bundles up to 100mm Ø	120	60
	Type C2, D1 & D2 electrical cables*	120	45
	Type A1, A3, C1 & D3 electrical cables*	120	60
125 x 125 to 125 x 1100	Electrical cables up to 80mm Ø	120	30
	Unsheathed wire up to 24mm Ø	120	30
	Telecoms cables in bundles up to 100mm Ø	120	60
	Type C2, C3, D1, D2 & E electrical cables*	120	45
	Type A1, A2, A3 & C1 electrical cables*	120	60

*Cables as referenced in EN 1366-3: 2009, Annex A, Tables A.1 and A.3. (See page 7).

Electrical cables in dry line or concrete block/masonry walls of minimum thickness 100mm with single layer of Insulwrap applied to exposed surfaces of Transit

Transit size (mm)	Penetrating service	Fire performance (mins)	
		Integrity (E)	Integrity & insulation (EI)
65 x 65, 102 x 102, 50, 100 & 150 Ø	Electrical cables up to 80mm Ø	120	30
	Unsheathed wire up to 24mm Ø	120	30
	Telecoms cables in bundles up to 100mm Ø	120	90
	Type C2, D1 & D2 electrical cables*	120	45
	Type A1, A2, C1 & D3 electrical cables*	120	60
125 x 125 to 125 x 1100	Type A3 electrical cables*	120	90
	Electrical cables up to 80mm Ø	120	30
	Unsheathed wire up to 24mm Ø	120	30
	Telecoms cables in bundles up to 100mm Ø	120	90
	Type C2, C3, D1, D2 & E electrical cables*	120	45
	Type A1, A2, C1 & D3 electrical cables*	120	60
	Type A3 electrical cables*	120	90

*Cables as referenced in EN 1366-3: 2009, Annex A, Tables A.1 and A.3. (See page 7).

Electrical cables in dry line or concrete block/masonry walls of minimum thickness 100mm with single layer of 300mm wide Insulwrap protection to cables both sides

Transit size (mm)	Penetrating service	Fire performance (mins)	
		Integrity (E)	Integrity & insulation (EI)
All sizes	Electrical cables up to 80mmØ	120	60
	Unsheathed wire up to 24mm Ø	120	60
	Telecoms cables in bundles up to 100mm Ø	120	60

Electrical cables in dry line or concrete block/masonry walls of minimum thickness 100mm with a single layer of 300mm wide Insulwrap protection to cables both sides and also applied to exposed surfaces of Transit

Transit size (mm)	Penetrating service	Fire performance (mins)	
		Integrity (E)	Integrity & insulation (EI)
65 x 65, 102 x 102, 50, 100 & 150 Ø	Electrical cables up to 80mm Ø	120	120
	Unsheathed wire up to 24mm Ø	120	60
	Telecoms cables in bundles up to 100mm Ø	120	120
125 x 125 to 125 x 1100	Electrical cables up to 80mm Ø	120	90
	Unsheathed wire up to 24mm Ø	120	60
	Telecoms cables in bundles up to 100mm Ø	120	120
	Type D2 & E electrical cables*	120	120

*Cables as referenced in EN 1366-3: 2009, Annex A, Tables A.1 and A.3. (See page 7).

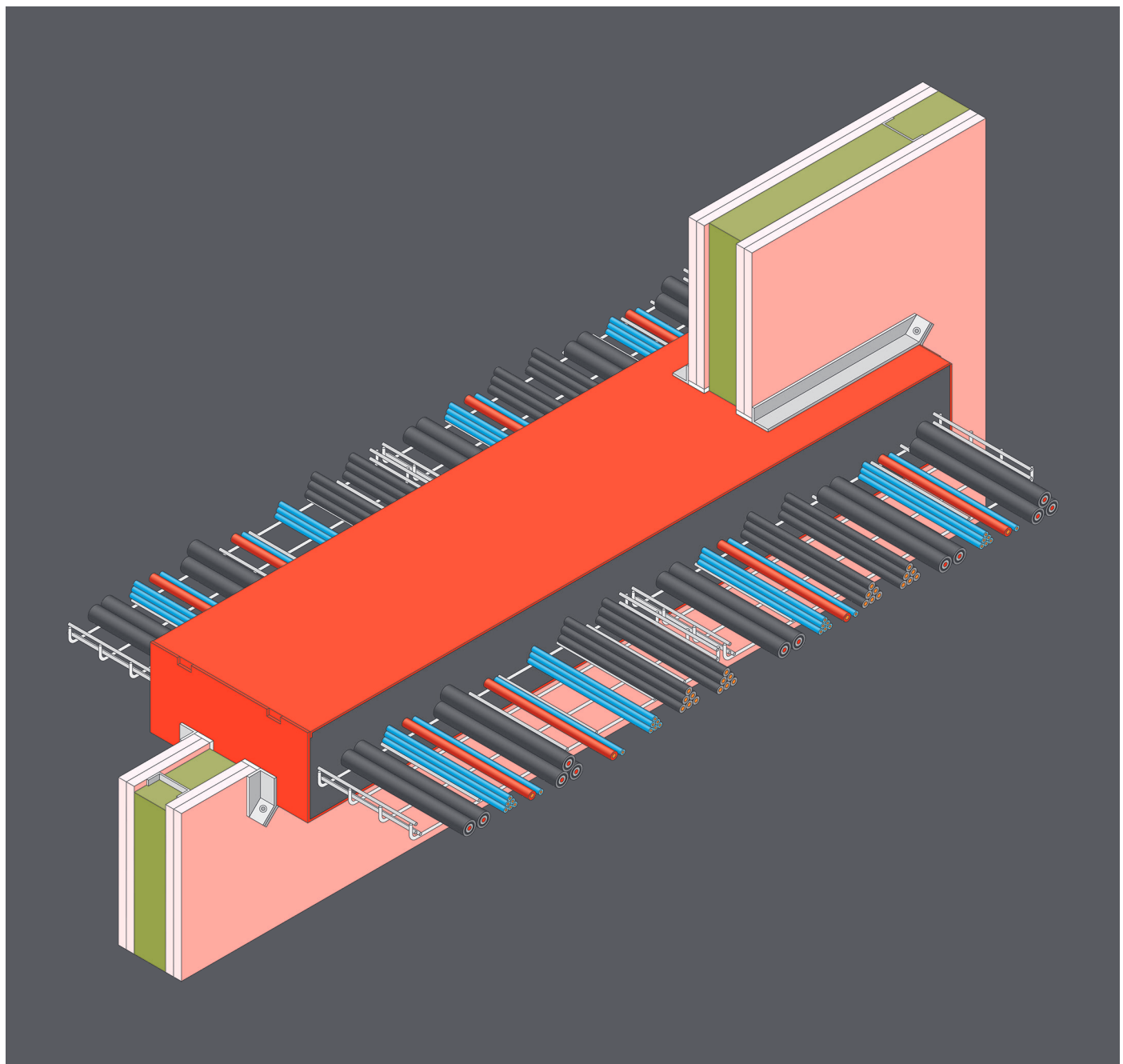

Continues on the next page.

Pipes in concrete block/masonry walls of minimum thickness 100mm

Transit size (mm)	Penetrating pipe	Max Ø (mm)	Min wall thickness (mm)	Insulation	Min insulation thickness (mm)	Fire performance (minutes)	
						Integrity (E)	Integrity & insulation (EI)
All sizes	PVC	82	3.2	N/A	N/A	120	90
		42	1.5		13	240	90
	Copper/steel	42	1.5	19	240	120	
		42	1.5	32	240	180	
		28	1.2	9	240	90	
		10	1.2	6	240	90	
		90	1.6	13	240	90	
	Steel	K-Flex ST or Armaflex (CS)	64	1.6	9	240	60
			64	1.6	13	240	90
			64	1.6	19	240	120
			64	1.6	32	240	180
			40	1.5	13	240	120
			40	1.5	25	240	180
		Other Steel	25	1.2	9	240	60
			25	1.2	13	240	90
			25	1.2	25	240	120
			10	1	6	240	90

(CS) = Continuous sustained

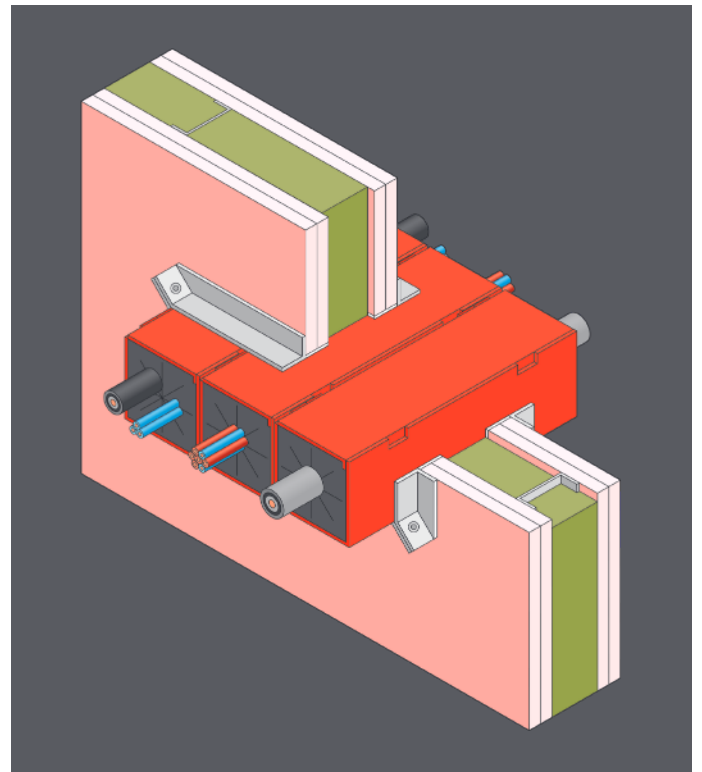
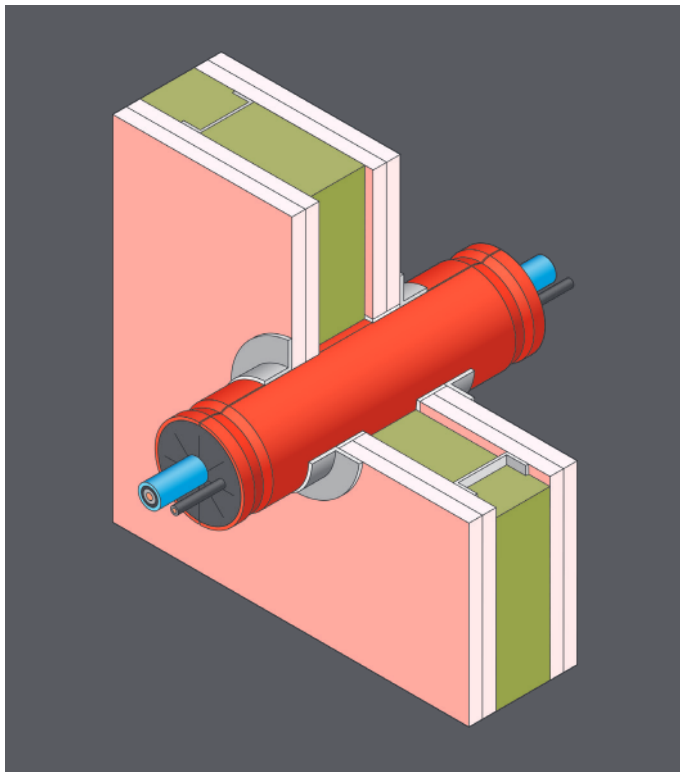

Continues on the next page.

Pipes in partition walls of minimum thickness 100mm

Transit size (mm)	Penetrating pipe	Max Ø (mm)	Min wall thickness (mm)	Insulation	Min insulation thickness (mm)	Fire performance (minutes)	
						Integrity (E)	Integrity & insulation (EI)
All sizes	PVC	82	3.2	N/A	N/A	120	90
		42	1.5		13	120	90
	Copper/steel	42	1.5	K-Flex ST or Armaflex (CS)	19	120	120
		28	1.2		9	120	90
		10	1.2		6	120	90
		90	1.6		13	120	90
		64	1.6		9	120	60
		64	1.6		13	120	90
	Steel	64	1.6	K-Flex ST or Armaflex (CS)	19	120	120
		40	1.5		13	120	120
		25	1.2		9	120	60
		25	1.2		13	120	90
		25	1.2		25	120	120
		10	1		6	120	90

(CS) = Continuous sustained

Electrical cables in concrete floors of minimum thickness 150mm

Transit size (mm)	Penetrating service	Fire performance (mins)	
		Integrity (E)	Integrity & insulation (EI)
65 x 65, 102 x 102, 50, 100 & 150 Ø	Electrical cables up to 80mm Ø	180	30
	Electrical cables up to 21mm Ø	240	60
	Telecoms cables in bundles up to 100mm Ø	240	60
	Type C3 electrical cables*	240	30
	Type C2 & D3 electrical cables*	240	45
	Type C1 & B electrical cables*	240	60
125 x 125 to 125 x 1100	Steel cable basket	180	180
	Electrical cables up to 80mm Ø	180	60
	Unsheathed wire up to 24mm Ø	180	60
	Telecoms cables in bundles up to 100mm Ø	180	180
	Type A3, C1, C2, D3 & G1 electrical cables*	180	60
	Type A1, B, D1, D2, E & G2 electrical cables*	180	90
	Type A2 & C3 electrical cables*	180	180

*Cables as referenced in EN 1366-3: 2009, Annex A, Tables A.1 and A.3. (See page 7).

Continues on the next page.

Electrical cables in concrete floors of minimum thickness 150mm with single layer of 300mm Insulwrap protection to cables on non-fire side only

Transit size (mm)	Penetrating service	Fire performance (mins)	
		Integrity (E)	Integrity & insulation (EI)
65 x 65, 102 x 102, 50, 100 & 150 Ø	Electrical cables up to 80mm Ø	180	45
	Electrical cables up to 21mm Ø	240	60
	Telecoms cables in bundles up to 100mm Ø	240	60
125 x 125 to 125 x 1100	Steel cable basket	120	120
	Electrical cables up to 80mm Ø	120	60
	Unsheathed wire up to 24mm Ø	120	60
	Telecoms cables in bundles up to 100mm Ø	120	120
	Type B & C1 electrical cables*	120	60
	Type E electrical cables*	120	90
	Type A1, A2, A3, C2, C3, D1, D2 & D3 electrical cables*	120	120

*Cables as referenced in EN 1366-3: 2009, Annex A, Tables A.1 and A.3. (See page 7).

Electrical cables in concrete floors of minimum thickness 150mm with single layer of Insulwrap protection applied to exposed surfaces of Transit on non-fire side

Transit size (mm)	Penetrating service	Fire performance (mins)	
		Integrity (E)	Integrity & insulation (EI)
65 x 65, 102 x 102, 50, 100 & 150 Ø	Electrical cables 51 to 80mm Ø	240	30
	Electrical cables 22 to 50mm Ø	180	30
	Electrical cables up to 21mm Ø	240	60
	Telecoms cables in bundles up to 100mm Ø	240	60

Electrical cables in concrete floors of minimum thickness 150mm with single layer of 300mm wide Insulwrap protection applied to cables on non-fire side and also applied to exposed surfaces of Transit on non-fire side

Transit size (mm)	Penetrating service	Fire performance (mins)	
		Integrity (E)	Integrity & insulation (EI)
65 x 65, 102 x 102, 50, 100 & 150 Ø	Electrical cables 51 to 80mm Ø	180	90
	Electrical cables 22 to 50mm Ø	240	90
	Electrical cables up to 21mm Ø	240	120
	Telecoms cables in bundles up to 100mm Ø	240	120
	Type A1, C1, C2, C3, D2 & D3 electrical cables*	240	120

*Cables as referenced in EN 1366-3: 2009, Annex A, Tables A.1 and A.3. (See page 7).

Continues on the next page.

Pipes in concrete floors of minimum thickness 150mm

Transit size (mm)	Penetrating pipe	Max Ø (mm)	Min wall thickness (mm)	Insulation	Min insulation thickness (mm)	Fire performance (minutes)	
						Integrity (E)	Integrity & insulation (EI)
All sizes	PVC	82	3.2	N/A	N/A	180	120
	Copper/steel	42	1.5	K-Flex ST or Armaflex (CS)	13	180	90
		42	1.5		40	180	120
	Steel	28	1.2		9	180	120
		90	1.6		13	180	120
	64	1.6	9		180	90	
	64	1.6	13		180	120	
	40	1.5	13		180	90	
	40	1.5	40		180	120	
	25	1.2	9		180	120	
10	1	6	180		120		

(CS) = Continuous sustained

Cables as referenced in EN 1366-3: 2009, Annex A, Tables A.1 and A.3

Title	Description
Type A1 cable	5x 1.5mm ² core HD603.3 electrical cable with PVC insulation, PVC sheath and 14mm Ø
Type A2 cable	5x 1.5mm ² core HD22.4 electrical cable with EPR insulation, PO sheath and 11.2–14.4mm Ø
Type A3 cable	5x 1.5mm ² core HD604.5 electrical cable with XLPE insulation, EVA sheath and 13mm Ø
Type B cable	1x 95mm ² core HD6.3.3 electrical cable with PVC insulation, PVC sheath and 18–21mm Ø
Type C1 cable	4x 95mm ² core HD604.5 electrical cable with XLPE insulation, EVA sheath and 42mm Ø
Type C2 cable	4x 95mm ² core HD22.4 electrical cable with EPR insulation, PO sheath and 48.4–61mm Ø
Type C3 cable	4x 95mm ² core HD604.5 electrical cable with XLPE insulation, EVA sheath and 42–45.5mm Ø
Type D1 cable	4x 185mm ² core HD603.3 electrical cable with PVC insulation, PVC sheath 52mm Ø
Type D2 cable	4x 185mm ² core HD22.4 electrical cable with EPR insulation, PO sheath and 64–80mm Ø
Type D3 cable	4x 185mm ² core HD604.5 electrical cable with XLPE insulation, EVA sheath and 13mm Ø
Type E cable	1x 185mm ² core HD603.3 electrical cable with PVC insulation, PVC sheath and 23–27mm Ø
Type F cable	20mm x 2mm x 0.6mm screened electrical cable with PVC insulation, PVC sheath and 15–17mm Ø
Type G1 wire	1x 95mm ² core H07V-R HD21.3 electrical wire with PVC insulation and 14.1–17.1mm Ø
Type G2 wire	1x 185mm ² core H07V-R HD21.3 electrical wire with PVC insulation and 19.3–23.3mm Ø

Continues on the next page.

Firebreak Service Transits dimensions and packaging details

Product code	Item	Pack size
31940	65 x 65 x 254mm long Firebreak Service Transit	6 units per box
31972	65mm mounting flange – single set	6 units per box
31974	65mm mounting flange – duplex set	3 units per box
31976	65mm mounting flange – triplex set	2 units per box
31977	65mm mounting flange – quadplex set	1 unit per box
31978	65mm mounting flange – sixplex set	1 unit per box
31942	102 x 102x 254mm long Firebreak Service Transit	6 units per box
31982	102mm mounting flange – single set	6 units per box
31984	102mm mounting flange – duplex set	3 units per box
31986	102mm mounting flange – triplex set	2 units per box
31987	102mm mounting flange – quadplex set	1 unit per box
31988	102mm mounting flange – sixplex set	1 unit per box
33250	250 x 125 x 254mm long Firebreak Service Transit	Each
33255	250mm ST mounting flange – single set	Each
33350	350 x 125 x 254mm long Firebreak Service Transit	Each
33355	350mm ST mounting flange – single set	Each
33450	450 x 125 x 254mm long Firebreak Service Transit	Each
33455	450mm ST mounting flange – single set	Each
33550	550 x 125 x 254mm long Firebreak Service Transit	Each
33555	550mm ST mounting flange – single set	Each
33110	1100 x 125 x 254mm long Firebreak Service Transit	Each
33510	1100mm mounting flange – single set	Each
31938	50mm Ø x 254mm long Firebreak Service Transit	6 units per box
31968	50mm Ø mounting flange – single set	6 units per box
31950	100mm Ø x 254mm long Firebreak Service Transit	6 units per box
31998	100mm Ø mounting flange – single set	6 units per box
31915	150mm Ø x 254mm long Firebreak Service Transit	5 units per box
31999	150mm Ø mounting flange – single set	5 units per box

Continues on the next page.

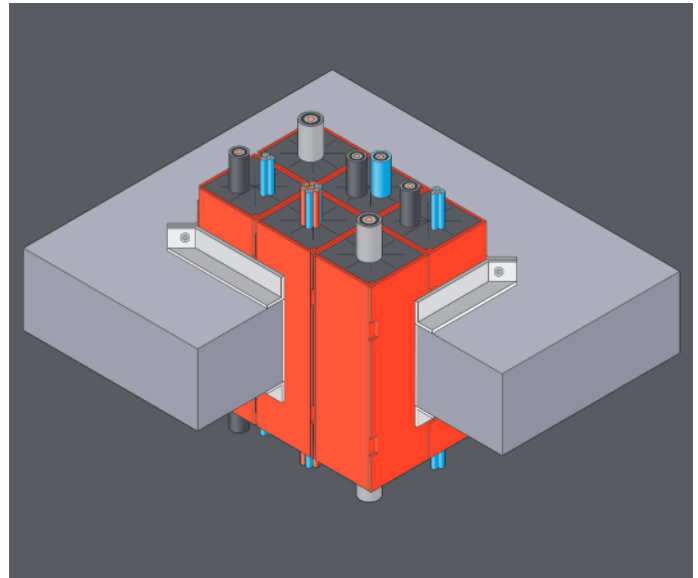
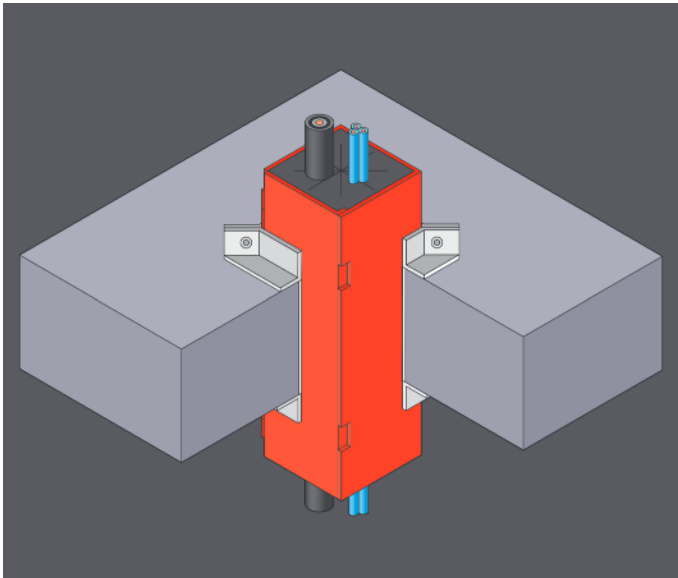

Installation – Transits

- Select Firebreak Service Transit to suit opening size
- Where necessary increase opening size to accommodate selected transit
- Ensure opening is clean and free from obstructions
- Remove and place to one side the foam plugs at each end of the transit and insert the transit into the opening
- Where the penetrating service is already present the lid of the transit should be opened to allow it to be fitted around the services
- Position the transit at mid depth within the wall/floor and seal any gaps around the transit on the first side using Firebreak 22 sealant or Firebreak Compound mixed to a trowellable consistency
- The latter is particularly useful where there is an existing opening significantly larger than the transit to be fitted
- Temporary support may be required in floor installations

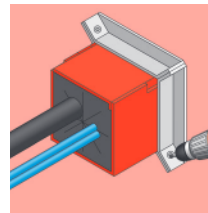
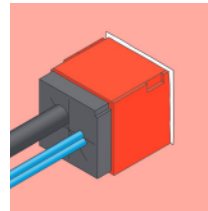
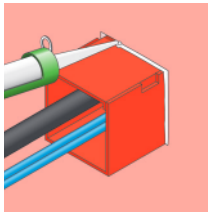
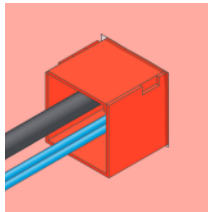
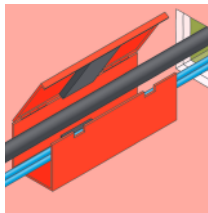
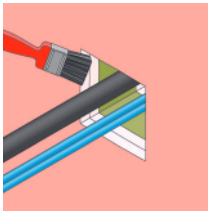

- Fit a pair of the steel mounting flanges around the transits hard up against the face of the wall/floor and screw together with the fixings provided
- The flanges may also be mechanically fixed to the face of the wall/floor through the screw openings but this is entirely optional
- Repeat the procedure of filling the opening around the transit and fixing the steel mounting flanges on the opposite side of the wall/floor
- Modify if necessary and refit the foam plugs tightly around the penetrating service at both sides of the seal to restrict the passage of cold smoke
- Additional plugs are readily available

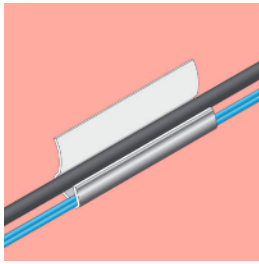

Installation– Insulwrap insulation

- Where required measure the circumference of the services penetrating the Transit
- Using a sharp knife or scissors cut a length of Insulwrap equal to the circumference measurement + 25mm to allow for a small overlap

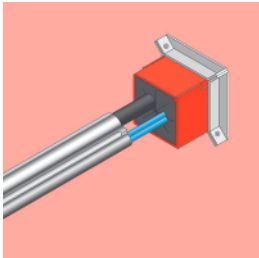

- Wrap the cut length of Insulwrap around the services with the foil on the outside and stick the small overlap down using a strip of self-adhesive aluminium tape or similar

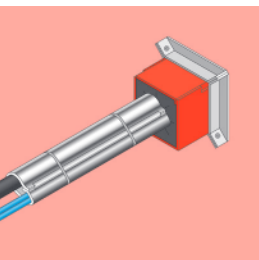

- Slide the Insulwrap along the services so that it butts up tightly against the face of the Transit
- Using stainless steel banding or wire further secure the insulwrap approximately 75mm from each end

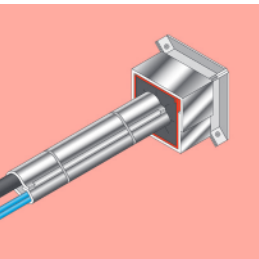

- Repeat the procedure on the other side of the seal
- If required the insulation performance of any exposed surfaces of the body of the Transit can also be increased



- Measure the width of the exposed body and cut lengths of Insulwrap to the same width and at the lengths required
- Apply a zig zag bead of Firebreak 1100 High Temperature Adhesive along the length of each exposed surface and fixed the strips of Insulwrap with the foil face showing

End use considerations

Whilst Firebreak Service Transits are intended for internal use they have been subjected to mechanical and durability testing and the intumescent components are not affected by moisture. The collars are also suitable for use at temperatures below 0°C.

Maintenance

No routine maintenance is required although periodic inspection for possible damage is recommended.

Storage

It is recommended to store in dry conditions between 5°C and 40°C.

Shelf life

Shelf life is unlimited when stored under recommended storage conditions.

Health and safety

Please refer to safety data sheet before use.

Since the product is applied under circumstances beyond our control, Neutron Fire Technologies Limited can accept no direct or consequential liability whether in contract or in tort, for the interpretations of such recommendations and reserves the right to modify the recommendations as necessary.

