

Firebreak 22 Fire Resistant Acoustic Sealant

TECHNICAL DATA SHEET

Firebreak 22 is an easy-to-apply, highly flexible polymer emulsion sealant designed to provide fire protection wherever internal low movement and/or acoustic joints are required. When exposed to high temperature it swells to form a durable char that restricts the passage of smoke and fire for up to 4 hours.

Description

Firebreak 22 is a halogen-free, polymer emulsion based sealant that swells when subjected to temperatures in excess of 125°C to form a durable char that restricts the passage of smoke and fire. It is easy to apply and is designed for internal use wherever low movement fire resistant and/or acoustic joints are required.

In addition, it has also been extensively fire tested to provide fire seals around a wide range of pipe and cable service penetrations through fire compartmenting floors and walls including 100mm thick flexible (plasterboard) partitions.

Performance

Firebreak 22 has been tested to the latest European requirements for applications in walls and floors. Testing to other national standards is also available.

- Fire classification to EN 13501-2 and CE Mark (ETA 21/0222 & 21/0213)
- Flexible Walls (stud partitions) or rigid walls (masonry, concrete) of 100mm minimum thickness

- Rigid (concrete) floors of 150mm minimum thickness
- Tested in conjunction with a wide range of common construction materials including masonry, steel, wood, bunched telecommunications cables, large power cables and steel and copper pipes
- +/- 12.5% movement capability (conforms to ISO 11600 F 12.5P)
- Mechanical and durability testing to EAD 350454-001104 & EAD 350141-00-1106; Z₂ (0/+70°C) (internal use with temperature range of 0°C to +40°C and high humidity)
- Third party product certification with UL International (Certificate # UL-EU-00597)
- Sound insulation: Rw up to 59dB (BS EN ISO 10140-2: 2010)
- Zero flame spread when tested to EN ISO 11925-2: 2010 giving Class E classification to EN 13501-1:2007 + A1



- VOC Emissions Classification: M1 (highest European classification)

Other properties

- Colour: White (other colours available in minimum order quantities)
- Specific gravity: 1.60 - 1.64
- Skinning time: 15 to 60 minutes depending on conditions
- Cure time: 5 to 15 days for a 20 x 15mm bead
- Hardness (Shore A): 25 – 30
- Painting: Can be over painted with most paints once fully cured



CE
2821
21
2821-CPR-0117
ETA 21/0222 & ETA 21/0213
EAD 350454-00-1104 & EAD 350141-00-1106

Linear gaps in masonry/concrete walls of minimum thickness 200mm

Maximum gap size (mm)	Seal position	Minimum seal depth (mm)	Backing material	Minimum backing depth (mm)	Fire performance (mins)	
					Integrity (E)	Integrity & insulation (EI)
10	Either side	12	PE or stone mineral wool	N/A	240	240
10	Either side	10	PE or stone mineral wool	N/A	240	180
10	Both sides	10	Stone mineral wool*	25	240	240
20	Either side	22	PE or stone mineral wool	N/A	240	120
20	Either side	20	PE or stone mineral wool	N/A	240	90
30	Either side	25	PE or stone mineral wool	N/A	240	60
30	Both sides	20	Stone mineral wool*	25	240	240
30	Both sides	15	Stone mineral wool*	25	240	180

*Nominal compressed density 90kg/m³.

Linear gaps in masonry/concrete walls of minimum thickness 150mm

Maximum gap size (mm)	Seal position	Minimum seal depth (mm)	Backing material	Minimum backing depth (mm)	Fire performance (mins)	
					Integrity (E)	Integrity & insulation (EI)
20	Both sides	10	PE or stone mineral wool	N/A	240	180
25	Both sides	12.5	PE or stone mineral wool	N/A	240	180
30	Both sides	15	PE or stone mineral wool	N/A	240	180
35	Both sides	17.5	PE or stone mineral wool	N/A	240	180
40	Both sides	20	PE or stone mineral wool	N/A	240	180
50	Both sides	10	Firebreak 44 foam	130	240	240
100	Both sides	10	Stone mineral wool*	130	240	240

*Nominal compressed density 90kg/m³.

Linear gaps in masonry/concrete walls of minimum thickness 100mm

Maximum gap size (mm)	Seal position	Minimum seal depth (mm)	Backing material	Minimum backing depth (mm)	Fire performance (mins)	
					Integrity (E)	Integrity & insulation (EI)
30	Both sides	10	PE or stone mineral wool	N/A	180	60
30	Both sides	15	PE or stone mineral wool	N/A	240	120
40	Both sides	20	PE or stone mineral wool	N/A	240	120
50	Both sides	10	Firebreak 44 foam	80	240	120

Linear gaps in partition to partition walls of minimum thickness 100mm or similar partition walls to masonry/concrete

Maximum gap size (mm)	Seal position	Minimum seal depth (mm)	Backing material	Minimum backing depth (mm)	Fire performance (mins)	
					Integrity (E)	Integrity & insulation (EI)
25	Both sides	10	Stone mineral wool*	80	120	120

*Nominal compressed density 90kg/m³.

Linear gaps in partition walls of minimum thickness 100mm to masonry/concrete

Maximum gap size (mm)	Seal position	Minimum seal depth (mm)	Backing material	Minimum backing depth (mm)	Fire performance (mins)	
					Integrity (E)	Integrity & insulation (EI)
20	Both sides	10	Stone mineral wool*	15	120	120
20	Both sides	25	Steel stud	N/A	120	120

*Nominal compressed density 90kg/m³.

Linear gaps against steel in masonry/concrete walls of minimum thickness 150mm

Maximum gap size (mm)	Seal position	Minimum seal depth (mm)	Backing material	Minimum backing depth (mm)	Fire performance (mins)	
					Integrity (E)	Integrity & insulation (EI)
30	Both sides	10	PE or stone mineral wool	N/A	240	90
50	Both sides	25	Stone mineral wool**	50	240	240

**Nominal compressed density 110kg/m³.

Linear gaps against steel in masonry/concrete walls of minimum thickness 100mm

Maximum gap size (mm)	Seal position	Minimum seal depth (mm)	Backing material	Minimum backing depth (mm)	Fire performance (mins)	
					Integrity (E)	Integrity & insulation (EI)
30	Both sides	10	PE or stone mineral wool	N/A	240	60
50	Both sides	25	Stone mineral wool**	50	240	120

**Nominal compressed density 110kg/m³.

Linear gaps against timber in masonry/concrete walls of minimum thickness 150mm

Maximum gap size (mm)	Seal position	Minimum seal depth (mm)	Backing material	Minimum backing depth (mm)	Fire performance (mins)	
					Integrity (E)	Integrity & insulation (EI)
30	Both sides	15	PE or stone mineral wool	N/A	180	180
50	Both sides	25	Stone mineral wool**	50	120	120

**Nominal compressed density 110kg/m³.

Linear gaps against timber in masonry/concrete walls of minimum thickness 100mm

Maximum gap size (mm)	Seal position	Minimum seal depth (mm)	Backing material	Minimum backing depth (mm)	Fire performance (mins)	
					Integrity (E)	Integrity & insulation (EI)
30	Both sides	20	PE or stone mineral wool	N/A	60	60
30	Both sides	15	Stone mineral wool*	70	120	120
50	Both sides	25	Stone mineral wool**	50	60	60

*Nominal compressed density 90kg/m³.

**Nominal compressed density 110kg/m³.

Linear gaps against timber in masonry/concrete walls of minimum thickness 92mm

Maximum gap size (mm)	Seal position	Minimum seal depth (mm)	Backing material	Minimum backing depth (mm)	Fire performance (mins)	
					Integrity (E)	Integrity & insulation (EI)
20	Both sides	10	Firebreak 44 foam	72	120	120

Linear gaps in concrete floors of minimum thickness 150mm

Maximum gap size (mm)	Seal position	Minimum seal depth (mm)	Backing material	Minimum backing depth (mm)	Fire performance (mins)	
					Integrity (E)	Integrity & insulation (EI)
10	Non-fire side	10	PE or stone mineral wool	N/A	240	120
20	Non-fire side	10	PE or stone mineral wool	N/A	240	60
30	Non-fire side	20	PE or stone mineral wool	N/A	120	60
30	Non-fire side	10	Stone mineral wool*	25	240	180
30	Both sides	10	PE or stone mineral wool	N/A	240	180

*Nominal compressed density 90kg/m³.

Linear gaps against steel in concrete floors of minimum thickness 150mm

Maximum gap size (mm)	Seal position	Minimum seal depth (mm)	Backing material	Minimum backing depth (mm)	Fire performance (mins)	
					Integrity (E)	Integrity & insulation (EI)
30	Both sides	10	PE or stone mineral wool	N/A	240	90

**Nominal compressed density 110kg/m³.

Linear gaps against timber in concrete floors of minimum thickness 150mm

Maximum gap size (mm)	Seal position	Minimum seal depth (mm)	Backing material	Minimum backing depth (mm)	Fire performance (mins)	
					Integrity (E)	Integrity & insulation (EI)
30	Both sides	10	PE or stone mineral wool	N/A	120	120
30	Both sides	15	Stone mineral wool*	120	180	180

*Nominal compressed density 90kg/m³.

Penetrations seals in flexible walls/partitions or masonry/concrete walls of minimum thickness 100mm

Max. opening size (mm)	Penetrating service	Seal position	Min. seal depth (mm)	Backing material	Min. backing depth (mm)	Fire performance (mins)	
						Integrity (E)	Integrity & insulation (EI)
400 x 400	Blank seal	Both sides	10	Stone mineral wool*	80	120	120
	Steel cable ladder/tray	Both sides	10	Stone mineral wool*	80	120	90
	HD604.5 cables up to 13mm dia., single/bunched	Both sides	10	Stone mineral wool**	80	120	60 (90)
	HD603.3 cables up to 14mm dia., single/bunched	Both sides	10	Stone mineral wool*	80	120	60 (90)
	HD22.4 cables up to 15mm dia., single/bunched	Both sides	10	Stone mineral wool*	80	120	45 (60)
	HD603.3 cables up to 21mm dia., single/bunched	Both sides	10	Stone mineral wool*	80	120	30 (60)
	HD604.5 cables up to 42mm dia., single/bunched	Both sides	10	Stone mineral wool*	80	120	60
	HD603.3 cables up to 42mm dia., single/bunched	Both sides	10	Stone mineral wool*	80	120	30 (45)
	HD603.3 cables up to 52mm dia., single/bunched	Both sides	10	Stone mineral wool*	80	120	30 (60)
	HD22.4 cables up to 61mm dia., single/bunched	Both sides	10	Stone mineral wool*	80	120	45 (60)
	Up to 19mm dia. copper/steel pipe + 25mm thick continuous mineral wool insulation	Both sides	10	Stone mineral wool*	80	120	120
	Up to 67mm dia. copper/steel pipe + 25mm thick continuous mineral wool insulation	Both sides	10	Stone mineral wool*	80	120	90
	16mm aluplex pipe	Both sides	10	Stone mineral wool*	80	120	120
	32mm aluplex pipe	Both sides	10	Stone mineral wool*	80	90	90
	54mm copper pipe	Both sides	10	Stone mineral wool*	80	90	90
	89mm steel pipe	Both sides	10	Stone mineral wool*	80	90	90
	32mm PVCU pipe	Both sides	10	Stone mineral wool*	80	120	120
	22mm PE pipe	Both sides	10	Stone mineral wool*	80	120	120
22mm PP pipe	Both sides	10	Stone mineral wool*	80	45	45	

* Nominal compressed density 90kg/m³.

Penetrations seals in flexible walls/partitions or masonry/concrete walls of minimum thickness 150mm

Max. opening size (mm)	Penetrating service	Seal position	Min. seal depth (mm)	Backing material	Min. backing depth (mm)	Fire performance (mins)	
						Integrity (E)	Integrity & insulation (EI)
120 dia.	HD604.5 cables up to 42mm dia., single/bunched	Both sides	15	Stone mineral wool**	25	240	120
90 dia.	HD603.3 cables up to 42mm dia., single/bunched	Both sides	15	Stone mineral wool**	25	240	60
110 dia.	Telecoms cables up to 21mm dia., single/bunched	Both sides	12	Stone mineral wool**	25	60	60
400 x 400	Steel armored cables up to 30mm dia., single/bunched	Both sides	10	Stone mineral wool*	130	120	60
	Up to 35mm dia. copper/steel pipe	Both sides	10	Stone mineral wool*	25	90	–
	Up to 35mm dia. copper/steel pipe + 19mm thick interrupted nitrile rubber insulation	Both sides	10	Stone mineral wool*	130	90	90
	Up to 89mm dia. copper/steel pipe	Both sides	10	Stone mineral wool*	130	120	30
	Up to 89mm dia. copper/steel pipe + 19mm thick interrupted nitrile rubber insulation	Both sides	10	Stone mineral wool*	130	120	120

*Nominal compressed density 90kg/m³. **Nominal compressed density 110kg/m³.

Penetration seals in concrete floors of minimum thickness 150mm

Max. opening size (mm)	Penetrating service	Seal position	Min. seal depth (mm)	Backing material	Min. backing depth (mm)	Fire performance (mins)	
						Integrity (E)	Integrity & insulation (EI)
120 dia.	Telecoms cables up to 21mm dia., single/bunched	Both sides	12	Stone mineral wool**	25	240	90
	HD604.5 cables up to 42mm dia., single/bunched	Both sides	20	Stone mineral wool**	25	120	60
90 dia.	HD603.3 cables up to 42mm dia., single/bunched	Both sides	15	Stone mineral wool**	25	120	45
110 dia.	BS7671–6944XLH cables up to 14mm dia., single/bunched	Both sides	10	Stone mineral wool*	130	240	120
	BS7671–6944LSH cables up to 19mm dia., single/bunched	Both sides	10	Stone mineral wool*	130	240	90
	BS7671–6944XLH cables up to 25mm dia., single/bunched	Both sides	10	Stone mineral wool*	130	240	90
350 x 150	Up to 19mm dia. copper/steel pipe + 25mm thick continuous mineral wool insulation	Both sides	10	Stone mineral wool*	130	240	240
	Up to 35mm dia. copper/steel pipe	Both sides	10	Stone mineral wool*	130	240	–
150 dia.	Up to 35mm dia. copper/steel pipe + 19mm thick interrupted nitrile rubber insulation (500mm minimum)	Both sides	10	Stone mineral wool*	130	240	180
	Up to 35mm dia. copper/steel pipe + 40mm thick interrupted mineral wool insulation (500mm minimum)	Both sides	10	Stone mineral wool*	130	240	180
120 dia.	Up to 35mm dia. copper/steel pipe	Both sides	15	Stone mineral wool*	25	240	180
350 x 150	Up to 63mm dia. copper/steel pipe + 25mm thick continuous mineral wool insulation	Both sides	10	Stone mineral wool*	130	240	180
150 dia.	Up to 89mm dia. copper/steel pipe	Both sides	10	Stone mineral wool*	130	240	15
	Up to 35mm dia. copper/steel pipe + 25mm thick interrupted nitrile rubber insulation (500mm minimum)	Both sides	10	Stone mineral wool*	130	240	120
300 dia.	Up to 219mm dia. steel pipe	Both sides	20	Stone mineral wool*	25	180	120

* Nominal compressed density 90kg/m³. ** Nominal compressed density 110kg/m³.

Packaging schedule

Item	Pack size (ml)	Items per box	Boxes per pallet		Items per pallet	
			Standard 4-way (1.2 x 1m)	Euro (1.2 x 0.8m)	Standard 4-way (1.2 x 1m)	Euro (1.2 x 0.8m)
Cartridge	310	25	64	48	1600	1200
Cartridge	310	12	132	100	1584	1200
Foil	600	12	78	72	936	864

Supply, packaging and usage

Firebreak 22 is normally supplied in 310ml cartridges or 600ml foil packs. It can also be supplied in 5, 10, 15 or 19 litre tubs to order.

The quantity of material required to seal a linear gap without allowance for wastage can

be calculated using the following equations with all dimensions measured in cm:

Gap width x seal depth x gap length/310
= number of 310ml cartridges required

Gap width x seal depth x gap length/600
= number of 600ml foils required

Note: Multiply by 2 where seal is to both faces of separating structure.

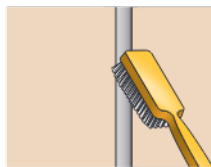
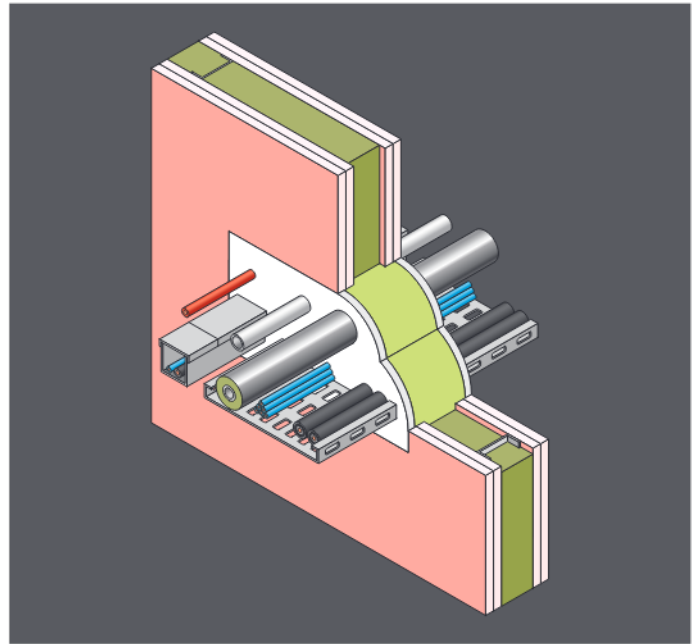
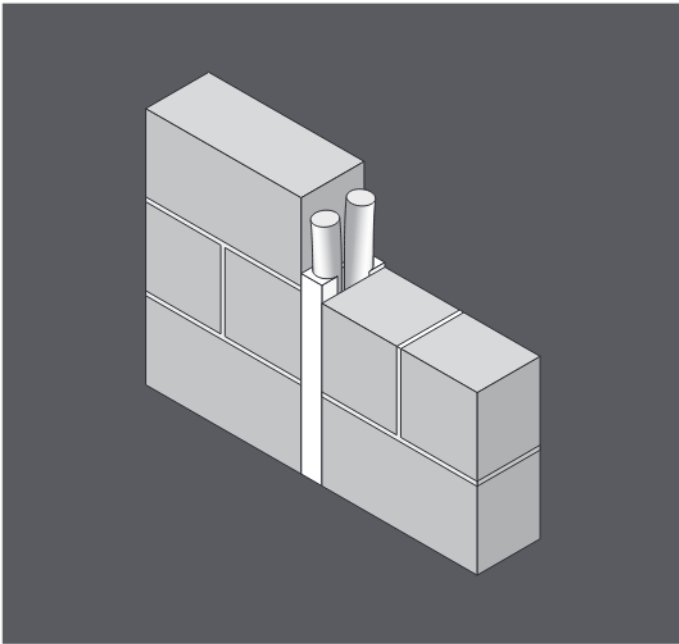

Installation

- Ensure contact surfaces are clean, dry and dust free
- Apply between 5°C and 40°C

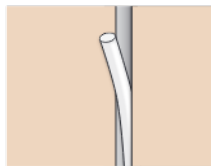

Linear gaps

- For linear gap applications insert backer rod or stone mineral wool, as determined by seal design, into the gap with a friction fit in order to control the required minimum depth of sealant

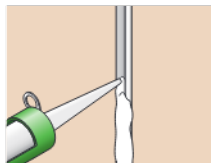

- Gun the sealant into the gap ensuring that the gap is fully filled and tool the surface smooth within 15 minutes using a dry pallet knife or spatula

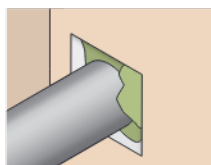

Service penetrations

- For service penetration seals pack stone mineral wool tightly around and between the services such that the opening is fully filled but leaving sufficient space at each face to apply the required minimum depth of sealant

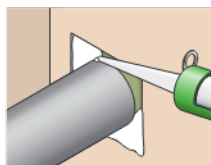

- Gun the sealant across the exposed faces of the seal ensuring that it is fully filled and tool the surface smooth within 15 minutes using a dry pallet knife or spatula

- Clean tools after use using water

Maintenance

No routine maintenance is required although periodic inspection for possible damage is recommended. All penetrations seals which are subsequently modified should be made good using Firebreak 22.

Storage

It is recommended to store in dry conditions between 5°C and 25°C.

Shelf life

24 months for unopened containers when stored under recommended storage conditions.

Health and safety

Please refer to safety data sheet before use.



Since the product is applied under circumstances beyond our control, Neutron Fire Technologies Limited can accept no direct or consequential liability whether in contract or in tort, for the interpretations of such recommendations and reserves the right to modify the recommendations as necessary.

